



COMMERCIAL RECYCLING & WASTE DISPOSAL



COMMERCIAL WASTE DISPOSAL

Clear Creek Disposal offers individualized service based on each business's needs. CCD collects commercial waste, but **ABSOLUTELY NO HAZARDOUS MATERIALS**. Call CCD with questions about potential hazards.

COST/BILLING:

Cost is based on the size and number of containers selected and the frequency of servicing. A CCD Customer Service Representative will assist business owners in developing cost effective, efficient servicing. Billing is monthly by CCD; except in Hailey where it is on City water bills.

COLLECTION SCHEDULE & FREQUENCY:

Collection service for commercial containers is available from a minimum of once a week, to a maximum of five days per week, Monday through Friday. Schedules vary depending on material(s) and collection container(s).



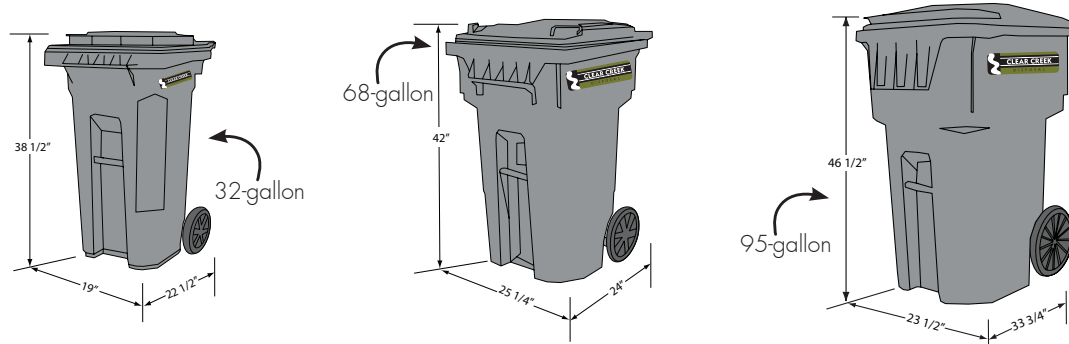

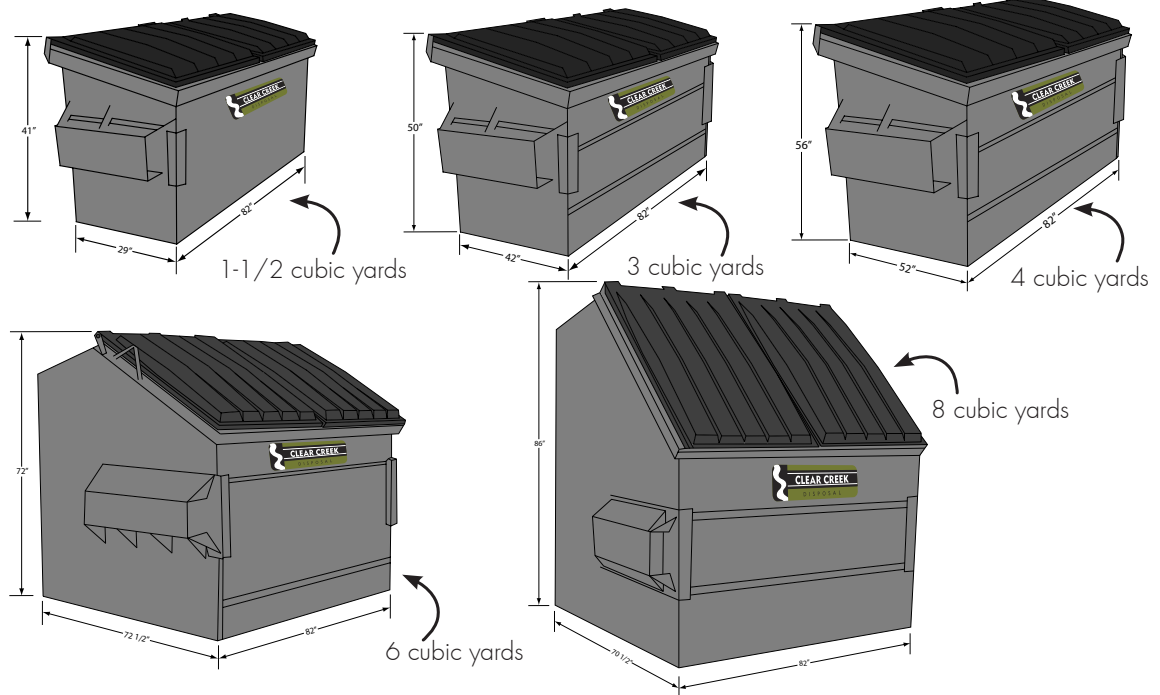

COLLECTION CONTAINER SIZE: Rolling Carts: 32-, 68- and 95-gallon



Dumpsters: 1-1/2, 3, 4, 6 and 8 cubic yards



Working for a Cleaner Environment and a More Prosperous Community

RECYCLABLE:	WHAT TO RECYCLE:	NO:
 <p>Corrugated Cardboard</p>	Flattened cardboard—the kind with the wavy middle.	Paper board (cereal-type boxes); Plastic film or Packing materials; Food-contaminated cardboard; Waxed cardboard.
 <p>Wood Waste</p>	Scrap lumber, pallets, untreated wood waste. Nails are OK. Land clearing wood waste. Max size: 18” diameter, 8’ length. (To be Chipped)	Plywood; Pressure-treated lumber; MDF or wood with glues.
 <p>Plastic Containers #1-5</p>	Rigid plastic bottles and containers, rinsed. Lids OK separate from container.	Bags; #6 polystyrene (aka Styrofoam); #7 other, Films; Wraps, Motor oil or other hazardous material containers; Buckets; Large items.
 <p>Food & Drink Cans</p>	Aluminum/Steel/Tin cans (soda, veggie, coffee, soup cans); Disposable-type Aluminum foil and pie tins; Rinsed. Minimal food contamination.	Aerosol cans; Propane bottles; Paint buckets; Metal pots; Cookie sheets; Large metal; Heavily soiled aluminum foil.
 <p>Glass</p>	All colors glass bottles and jars. (Glass is diverted, not recycled.)	Hazardous chemical containers; Plate glass; Pyrex; Light bulbs; Ceramics. (Labels & metal neck rings OK.)
 <p>Mixed Paper</p>	Newspaper (clean); Printer paper; Copier paper	Packing paper; Fluorescent color papers; Corrugated cardboard; Wax-coated paper such as milk/juice cartons; Spiral or bound papers; Books. Junk mail; Magazines and Catalogs (glue- and staple-back); Cereal boxes; colored and glossy paper; Paper bags; Paper 6-pack holder; Paper egg cartons; Papertowel holder tubes; Phone books.

ESTABLISHING SERVICE: CCD will assist businesses in establishing recycling collection. We will provide details on desired materials, what is considered “contamination,” and make recommendations on how each business can effectively and efficiently collect recyclables and reduce waste.

COLLECTION CONTAINERS: CCD provides an extensive selection of containers for all your recycling needs. 32-

68- and 95-gallon carts are available. Large generators of cardboard can utilize 1-1/2, 3, 4, 6 and 8 cubic yards dumpsters.

DROP-OFF RECYCLING: For businesses not wanting collection containers, cardboard and glass can be delivered to a community drop-off recycling locations in Bellevue, Hailey, Ketchum, and Sun Valley (all materials except glass). All commodities can be delivered to the Blaine County Recycle Center.

EVENT SERVICES: CCD offers portable toilets, portable storage, and hand wash stations, in addition to waste and recycling collection. Call us for assistance in selecting options that work for your occasion.

CLEAR CREEK DISPOSAL
www.ccdisposal.com • 208.726.9600